



# Reference Only

REPUBLIC FASTENER MANUFACTURING CORPORATION  
 1300 RANCHO CONEJO BOULEVARD, NEWBURY PARK, CALIFORNIA 91320 (805) 498-6621

"T" THREAD CLASS 3B  
 MIL-S-8879

SELF-LOCKING NUT

CLIP

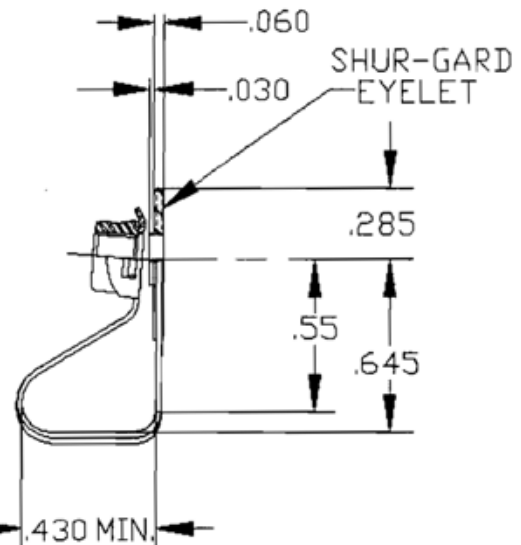
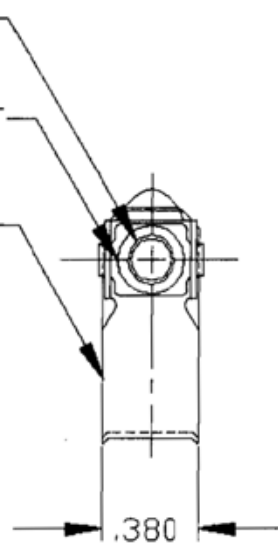

TABLE 1

FIRST DASH NO:	T THREAD	EDGE DISTANCE	INSTALLATION HOLE SIZE	APPROX. WEIGHT LB/100
-06	.1380-32 UNJC-3B	.55	.190-.229	.52
-08	.1640-32 UNJC-3B	.55	.190-.229	.57
-3	.1900-32 UNJF-3B	.55	.220-.230	.56

**MATERIAL:**

CLIP \_\_\_\_\_ CARBON STEEL, 1050 PER AMS5085, HEAT TREATED.  
 NUT \_\_\_\_\_ CARBON STEEL, 1050 PER AMS5085, HEAT TREATED.  
 EYELET \_\_\_\_\_ NYLON

**SURFACE TREATMENT:**

CLIP \_\_\_\_\_ CADMIUM PLATE PER QQ-P-416 TYPE II, CLASS 1.  
 NUT \_\_\_\_\_ CADMIUM PLATE PER QQ-P-416 TYPE II, CLASS 2,  
 MOLYBDENUM DISULFIDE DRY FILM LUBRICANT PER  
 MIL-L-46010  
 EYELET \_\_\_\_\_ NATURAL

NUT ELEMENT CONFORMS TO MIL-N-25027

**EXAMPLE OF PART NUMBER WITH EXPLANATION OF CODING:**

SL259-08 SP( )

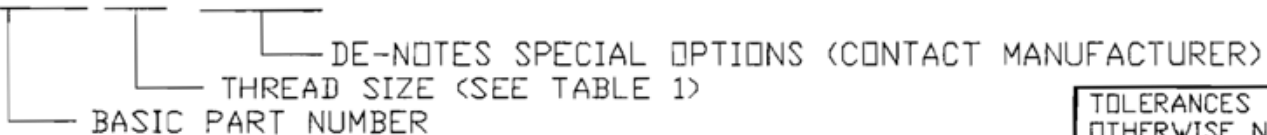

TOLERANCES UNLESS OTHERWISE NOTED:  
 DECIMALS: XX ±.020  
 XXX ±.010  
 ANGULAR: ±0°30'

APPROVED BY: UPP

TITLE

CLIP NUT, SELF LOCKING  
 SHUR-GARD

SALES DRAWING NO:  
 SL259 SERIES

REV. C DATE: 9-9-93

CAGE 52828